

IEEE Standard Test Procedure for Single-Phase Induction Motors

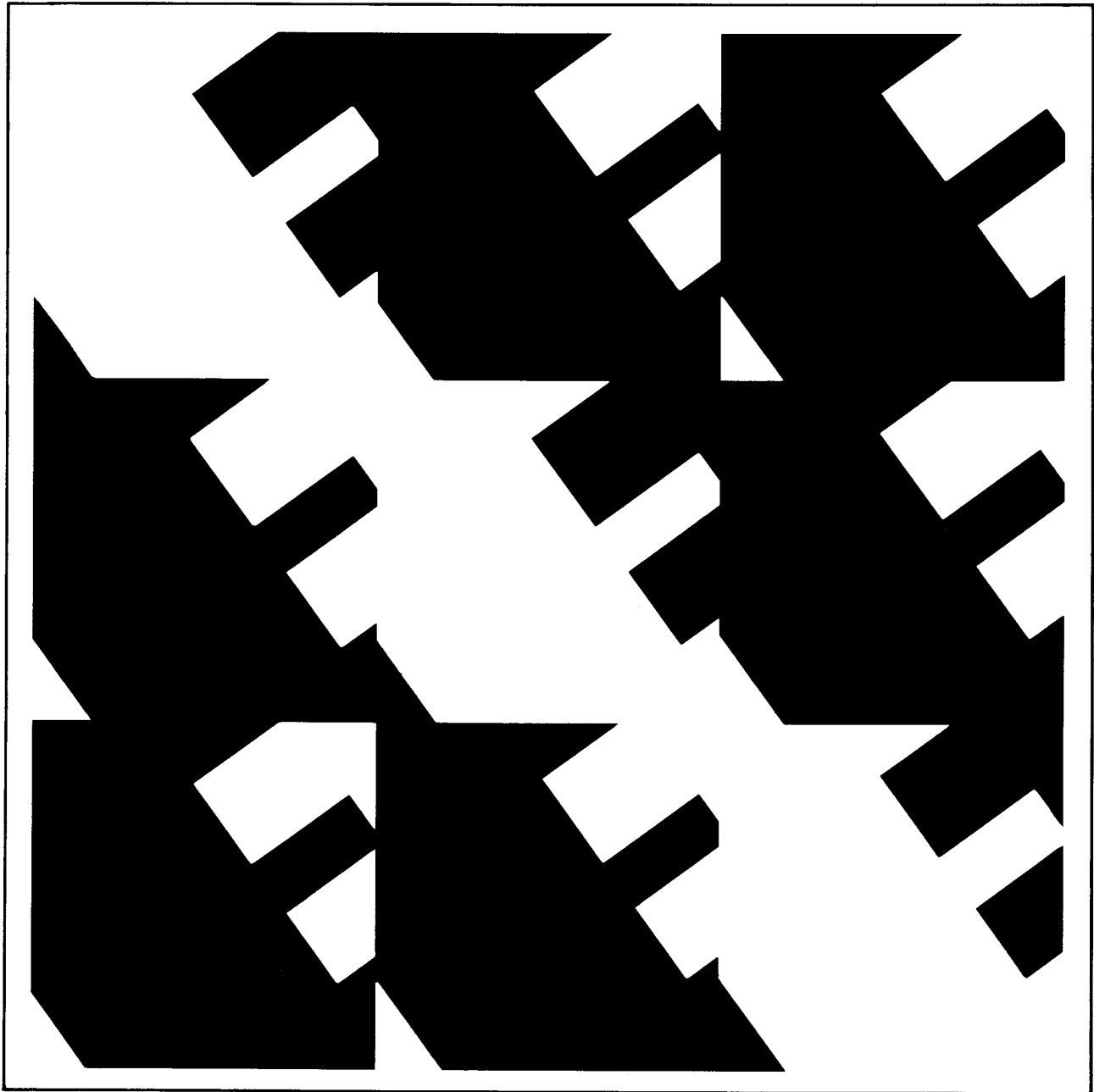

ANSI/IEEE Std 114-1982



Published by The Institute of Electrical and Electronics Engineers, Inc 345 East 47th Street, New York, NY 10017, USA
December 7, 1982

SH08938

IEEE Standard Test Procedure for Single-Phase Induction Motors

1. Scope

This standard covers instructions for conducting and reporting the more generally applicable and acceptable tests to determine the performance characteristics of single-phase motors, including nonexcited synchronous motors. It is not intended that this standard shall cover all possible tests used in production or tests of a research nature. The standard shall not be interpreted as requiring the making of any or all of the tests described herein in any given transaction.

2. References

- [1] ANSI/IEEE Std 4-1978, IEEE Standard Techniques for High-Voltage Testing
- [2] ANSI/IEEE Std 43-1974 (R1979), IEEE Recommended Practice for Testing Insulation Resistance of Rotating Machinery
- [3] ANSI/IEEE Std 100-1977, IEEE Standard Dictionary of Electrical and Electronics Terms
- [4] ANSI/NEMA MG 1-1978, Motors and Generators¹
- [5] IEEE Std 1-1969, IEEE General Principles for Temperature Limits in the Rating of Electric Equipment
- [6] IEEE Std 85-1973 (R1980), IEEE Test Procedure for Airborne Sound Measurements on Rotating Electric Machinery
- [7] IEEE Std 118-1978, IEEE Standard Test Code for Resistance Measurement

¹ ANSI documents are available from the Sales Department of American National Standards Institute, 1430 Broadway, New York, NY 10018.

[8] IEEE Std 119-1974, IEEE Recommended Practice for General Principles of Temperature Measurement as Applied to Electrical Apparatus

[9] IEEE Std 120-1955 (R1972) (ASME PTC 19.6-1955), Master Test Code for Electrical Measurements in Power Circuits

3. Tests

Single-phase induction motors are normally given a routine test but may be given a complete test.

3.1 Routine Test. The routine test includes measurement of power and current input at no-load and at rated voltage, current input with locked rotor at rated voltage, and a high-potential test. A suggested form for reporting such test data is shown in Form 1, on page 22 of this standard.

3.2 Complete Test. The complete test includes all of the data taken during a routine test plus the data necessary for determining efficiency, power factor, starting torque, pull-up torque, breakdown torque, rated-load slip, and rated-load temperature rise. A suggested test form for reporting data is shown in Form 2. Additional tests to determine locked-rotor temperature rise, speed-torque characteristics, shaft current, noise, and vibration may also be conducted.

3.3 Schedule of Tests. Input-output data may be obtained by any of the four following methods:

- Method A — brake
- Method B — dynamometer
- Method C — rope (or cord) and pulley
- Method D — continuous data acquisition (plotter)

Table 1
Tests Applicable to Single-Phase Motors

	(a)	(b)	(c)	(d)	(e)	(f)	(g)	(h)	(i)	(j)	(k)
Capacitor (permanent split)	x	x	x			x		x	x	x	x
Capacitor (two-value)	x	x	x	x		x		x	x	x	x
Capacitor- start	x	x	x	x		x		x	x	x	x
Split-phase	x	x	x	x		x		x	x	x	x
Shaded-pole	x	x	x			x		x	x	x	x
Repulsion	x	x						x	x	x	x
Repulsion- induction	x	x	x			x		x	x	x	x
Repulsion- start- induction	x	x	x	x		x		x	x	x	x
Reluctance (synch)	x	x	x		x	x	x	x	x	x	x
Universal*	x	x						x	x	x	x

*The tests listed apply to operation on alternating current only.

The quantities which may be measured are as follows:

- (a) Locked-rotor current
- (b) Locked-rotor torque
- (c) Pull-up torque
- (d) Switching torque
- (e) Pull-in torque
- (f) Breakdown torque
- (g) Pull-out torque
- (h) Speed
- (i) Power factor
- (j) Efficiency
- (k) Temperature rise

NOTE: The definitions for items (a) through (k) can be found in ANSI/IEEE Std 100-1977 [3].²

Items (h) through (k) are usually measured at rated power output. They may, however, be measured at any load required.

Table 1 lists the common types of single-phase motors and the tests that are applicable to each one.

3.4 General. After the method (A, B, C, or D) of test has been chosen, all necessary data may be obtained by following the instructions and precautions given only in those paragraphs which contain, in their headings, the letter

designating the method chosen. For example, when testing by Method B, reference needs to be made only to the paragraphs opposite the letter *B* or the word *All*, which is employed to designate paragraphs common to all methods. Some of these paragraphs include alternative methods of obtaining the necessary data and the manufacturer may choose the method best suited to the facilities available in such cases, unless otherwise specified.

Inasmuch as the performance of a single-phase motor is dependent not only upon the value of voltage and frequency but also upon the waveshape of the voltage, correct data can be obtained only by careful measurement and the use of a suitable source of power (see 4.1).

4. Electrical Measurements

4.1 (*All*)³ Power Supply

4.1.1 (*All*). The supply voltage shall closely approach sine waveform. The frequency shall be closely regulated. The frequency shall be measured by an accurate frequency meter or by an accurate tachometer driven by a synchronous motor operating on the same power

² The numbers in brackets correspond to the references listed in Section 2 of this standard.

³ Use of the word *all* and the letters *A*, *B*, *C* and *D* in subsection titles is explained in 3.4.

supply. The voltage waveform deviation factor, as defined in ANSI/IEEE Std 100-1977 [3], shall not exceed 10%. The equivalent sine wave referred to is a sine wave having the same frequency and root-mean-square values as the wave being tested.

4.1.2 (All). Rapid changes in frequency cannot be tolerated in input-output tests because such changes in frequency cause changes in speed and the variations are transmitted to the output-measuring device. Any departure from the assumed frequency directly affects the efficiency. The frequency shall be measured (or known to be) within an accuracy of 0.1%.

4.2 (A, B, C) Instrument Selection. The instruments used in electrical measurements shall be selected to give indications well up on the scale; that is, where a fraction of a division is easily estimated and where such a fraction is a small percentage of the value read. Further information regarding the use of instruments can be obtained by referring to IEEE Std 120-1955 [9].

4.3 (D) Transducer Selection. The transducers used in electrical measurements by continuous data acquisition (by plotter) shall be selected to give indications well up on the scale; that is, full scale on the plotter shall correspond as much as possible to full scale for the transducer. The time constant of the transducer selected shall be adequate for the particular output device (plotter). The internal losses of the transducer should be shown to be negligible when compared to the magnitudes being measured.

4.4 (All) Instrument Transformers. When current and potential instrument transformers are used, corrections shall be made for ratio errors in voltage and current measurements and for ratio and phase-angle errors in power measurement. The use of instrument transformers shall be avoided if possible. (See IEEE Std 120-1955 [9].)

4.5 (All) Voltage. The voltage shall be read at the motor terminals. Means should be provided whereby the voltage can be adjusted to the desired value. This control can be effected by the use of a continuously variable transformer or autotransformer, by an induction regulator, or by a controlled motor-generator set.

4.6 (All) Current. The line current of the motor shall be measured by an accurate am-

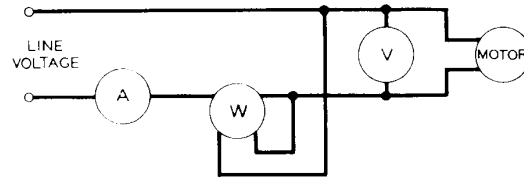

Fig 1
Preferred Meter Arrangement

meter or current transducer. The circuit diagram, Fig 1, shows the preferred arrangement of meters.

The motor current is the line current corrected by subtracting from it the currents taken by the voltmeter and the wattmeter voltage coils and may be computed by using one of the following equations:

$$P = P_w - \frac{E^2}{R_M}$$

$$I = \sqrt{I_A^2 - \frac{2P_w}{R_M} + \left(\frac{E}{R_M}\right)^2}$$

But

$$I_A \geq 7 \frac{E}{R_M}$$

$$I = I_A - \frac{P_w}{I_A R_M}$$

may be used.

In these equations

I_A = current (in amperes) indicated by ammeter A

I = net current, true input to motor

P_w = power (in watts) indicated by wattmeter W

P = net power (in watts) true input to motor

E = voltage (in volts) indicated by voltmeter V

R_M = resistance (in ohms) of the voltmeter and wattmeter voltage coils in parallel

4.7 (All) Power. A single-phase wattmeter or power transducer shall be used. The total watts read on the wattmeter, which shall be connected as shown in 5.5, shall be reduced by the amount of the power lost in the voltage circuit of the instruments unless the wattmeter is of the self-compensating type. Where a

properly selected power transducer is used, the transducer loss shall be shown to be negligible. All instruments must be read as simultaneously as practical.

5. Performance Determination

5.1 (All) Temperature. All performance determinations should be made in an ambient with a temperature as close as possible to 25 °C. The ambient temperature should be between 20 °C and 30 °C, unless otherwise agreed to by the purchaser and manufacturer.

Locked-rotor and breakdown torque tests should be made with the motor temperatures as close to ambient temperature as possible. Other performance data should be obtained with the motor operating as close as possible to its normal operating temperatures, unless otherwise agreed to by the purchaser and manufacturer. (See IEEE Std 119-1974 [8] for temperature corrections.)

5.2 (All) Efficiency. Efficiency is the ratio of output power to input power. The electric power is measured directly. The output power may be measured by Method A, B, C or D. Unless otherwise specified, the efficiency shall be determined at rated voltage, frequency, and temperature rise or actual temperature rise as determined by heat run. If a curve of efficiency versus output power is to be plotted, a minimum of seven points is recommended.

5.2.1 (A, B, C) Direct-Measurement Methods. In all direct-measurement tests the electric and mechanical powers are to be measured directly. The differences between Methods A, B, and C lie in the methods of measuring mechanical power. Readings of power, current, voltage, frequency, slip, torque, ambient temperature, and stator coil end-winding temperature or stator winding resistance shall be obtained for no-load and at least six load points substantially equally spaced from $\frac{1}{4}$ to $1\frac{1}{2}$ times rated load. The motor performance shall be determined as is outlined in Form 3 (see page 24).

5.2.1.1 (A) Method A — Brake. In this method a brake is mounted on the motor shaft and so arranged that a scale will read the retarding force offered by the brake. The torque is computed from the product of the scale reading and the brake arm length. Care shall be exercised in the construction and use of the

brake and the brake pulley. The *tare*, if present, shall be determined and compensated. Performance of a motor shall be calculated as shown on Form 3.

5.2.1.2 (B) Method B — Dynamometer. In this method the motor is connected to a dynamometer usually by means of flexible coupling. The dynamometer is free to rotate and has a torque arm which rests on a scale. The torque output of the motor is a product of the scale reading and the distance from the center of the dynamometer to the point where the torque arm makes contact with the scale. To obtain the mechanical power output of a motor by the dynamometer method the following equation may be used:

$$\text{power (in watts)} = \frac{T \cdot n}{k}$$

in which

$$\begin{aligned} n &= \text{rotational speed in r/min} \\ k &= 7.043 \text{ for } T \text{ in lb}\cdot\text{ft} \\ &= 84.52 \text{ for } T \text{ in lb}\cdot\text{in} \\ &= 112.7 \text{ for } T \text{ in oz}\cdot\text{ft} \\ &= 1352 \text{ for } T \text{ in oz}\cdot\text{in} \\ &= 9.549 \text{ for } T \text{ in N}\cdot\text{m} \end{aligned}$$

5.2.1.3 (C) Method C — Rope and Pulley. In this method a small rope or cord suspended from a spring scale is wrapped around the motor pulley a sufficient number of times so that when the cord is tightened by a small pull on its free end the scale will measure the motor's pull. If the cord is properly adjusted with negligible tension in the free end, the motor will just pull through the minimum torque points and the scale swings will be slow enough so that even the minimum torque in one slow revolution will be obtained. This method may be used to test a motor under load also if the motor power output is not great enough to damage the cord. To obtain accurate results, the following conditions must be fulfilled:

(1) Force may not be exerted on the free end of the cord unless the magnitude of the force is known and a correction for it is made. A distinct curvature in the free end of the cord as it leaves the pulley is the only conclusive evidence that there is no force.

(2) The pulley face should be wide enough to develop the required torque with a single layer of turns of the cord. If a single layer is not practicable, multiple layers may be used but

the first two turns on the scale end of the cord must be single-layer.

(3) The pulley must be in proper alignment with the scale so that there is no scale error caused by a nonrecording component of force in the cord. The alignment must also be such that there is a clearance between the cord and the pulley flange.

5.2.1.3.1 Method C — Correction for Cord Diameter. In calculating the torque, the radius at which the force is applied is to be taken as the pulley radius plus the cord radius. The cord diameter should be measured with the cord under tension. The micrometer anvil and spindle should have flat faces large enough to span at least two strand pitches. Sufficient pressure should be applied to flatten minor irregularities in the cord. Inasmuch as the cord diameter may change because of wear or stretch, the ratio of cord diameter to pulley diameter should be as small as practicable.

5.2.1.3.2 Method C — Correction for Pulley Windage Loss or for Dynamometer Windage Loss. The measured values of torque are to be corrected by adding to them a torque corresponding to the pulley windage or the dynamometer windage loss. The allowance for this loss is made by adding a torque T_W :

$$T_W = \frac{k(P_A - P_B)}{n} - T_D$$

in which

P_A = watts input to the motor driving the pulley or dynamometer

P_B = watts input to the motor without the pulley or dynamometer

n = rotational speed in r/min

k = 7.043 for T in lb·ft

= 84.52 for T in lb·in

= 112.7 for T in oz·ft

= 1352 for T in oz·in

= 9.549 for T in N·m

5.2.1.3.3 Method C — Determination of Friction and Windage Loss. When motors are supplied without bearings by the motor manufacturer it may be desirable to quote the efficiencies on the basis of a specified friction and windage loss and to consider the losses to be charged against the driven device. In such a case it is the usual practice to test the parts in a jig or fixture which does have friction in the bearings. The amount of this friction and windage is then separately determined and added to the motor output. For accurate results, the

friction of this jig or fixture should be low even though a correction is made inasmuch as the jig friction may change while a test is in progress.

5.2.1.3.4 Method C — Dynamometer Method of Measuring Friction and Windage. One method of determining the friction and windage losses is to measure the torque required to drive the parts at normal speed by means of a dynamometer. The friction P_f is then expressed, in watts, as:

$$P_f = \frac{T_f \cdot n}{k}$$

in which

T_f = net friction torque

k = same values as used in 5.2.1.3.2

n = rotational speed in r/min

The dynamometer used for this test should be such that the measured friction torque T_f represents at least 15% of the normal torque capacity of the dynamometer.

5.2.1.3.5 Method C — No-Load Saturation Method of Determining Friction and Windage Loss. The motor is run at no-load at normal frequency and voltage until the power input is constant to assure that the temperature of the oil or grease and the bearing friction have become constant. Readings are taken of volt, ampere, and watt input at rated frequency but with voltages ranging from 125% of rated voltage down to a point where further voltage reduction increases the current. The voltage adjustment is accomplished preferably by a variable-voltage transformer. Immediately following this test and before the temperatures can change sensibly, a reading of input power P_f and input current I_A at 50% or 60% of rated voltage should be taken with the rotor locked and with only the main or running winding excited. This test should be followed immediately by a measurement of the stator resistance R_1 .

If the input current at any voltage is I_s , the total copper loss P_c in the machine at the same voltage is:

$$P_c = \frac{I_s^2}{2} \left(R_1 + \frac{P_f}{I_A^2} \right)$$

The copper loss so calculated should be subtracted from the total input power at the same voltage. The resultant values may then be plotted against applied voltage with an extrap-

olation to zero voltage where the intercept represents the friction power. Extrapolation of the curve is facilitated by plotting the input power less the copper loss against voltage squared rather than against voltage.

For most practical purposes the friction can be measured with sufficient accuracy by reading simply the minimum power input as the voltage is reduced and then subtracting the copper loss as calculated by the formula.

5.2.1.3.6 Method C — Retardation Method of Determining Friction and Windage Loss. For this method, the rotational moment of inertia of the rotating parts must be known either by calculation or by measurement. The motor is run at no-load and at rated voltage and frequency until the power input is constant. The motor is then disconnected from the line and allowed to decelerate. The length of time required for the speed to decrease by some fixed interval, such as 100 r/min, is measured. From the rate of deceleration and using rotational inertia parameters, the friction and windage loss is readily calculated by the following equation:

$$P_f = kJn \frac{dn}{dt}$$

in which

P_f = friction and windage loss, watts at speed n

$\frac{dn}{dt}$ = rate of deceleration, revolutions per minute per second

n = speed at which rate of deceleration is known, revolutions per minute

J = polar moment of inertia of rotor assembly

$k = 4.621 \cdot 10^{-4}$ for J in lb·ft²
 $= 109.7 \cdot 10^{-4}$ for J in kg·m²

When this method is applied to fractional-horsepower motors, it is recommended that the speed be measured by visual means.

5.2.1.3.7 Method C — Duplicated Speed Method of Determining Friction and Windage Loss. While the motor is operated at rated output as described in 5.4, readings of input power and speed are taken. The load is then removed and the motor is allowed to operate at no-load. The voltage is then reduced until the speed is exactly the same as it was at rated output at rated voltage. The power input is again read. The last power input reading multiplied by the rated load efficiency of the motor is equal to the friction and windage loss.

5.2.2 (D) Continuous Data Acquisition Method. In this method the motor is coupled to a loading device which may be a dynamometer, brake or inertia load, through an appropriate coupling. Torque can be measured at the load by a dynamometer, in line by a rotating shaft torque sensor, or at the motor by stator reaction. All measured quantities, electrical or mechanical, are translated into standard signals by means of transducers for continuous input to a data output or storage device. Error in torque reading due to inertia is a function of acceleration and adequate corrections must be applied.

5.2.3 (D) Plotter Method. Where the data output device is an XY plotter, the test method is known as a plotter test method. A dependent variable is usually plotted as a function of an independent variable. The independent variable may be any of the measured quantities listed in 3.3 and in addition may be time or shaft angular position. Normally the independent variable is either speed or torque. The test may be repeated in a sequential mode plotting each dependent variable one at a time, or if all dependent functions are taken simultaneously, these functions may be stored and plotted sequentially.

5.3 Apparent Efficiency. Apparent efficiency is the ratio of watts output to voltamperes input.

5.4 (All) Tests with Load. Tests with load are made for the purpose of determining efficiency, power factor, speed, and temperature rise. Some of the miscellaneous tests outlined in Section 8 are also made with load. For all tests with load the machine shall be properly aligned and securely fastened. For readings to be used in performance determinations, the machine temperature rise shall be at or near rated temperature rise. The usual procedure is to take readings at higher loads first and follow with readings at lower loads.

5.5 Circuit Connections. The connections between the power source and the motor on test shall be as shown in Fig 2.

5.6 (All) Tests with Rotor Locked. It should be recognized that the testing of induction motors under locked-rotor conditions involves unusual mechanical stresses and high rates of heating. Therefore, the following precautions are necessary:

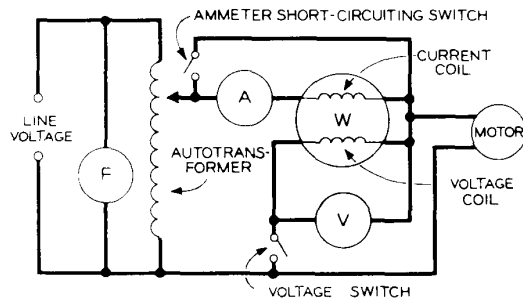

Key:
F = frequency meter V = voltmeter
A = ammeter W = wattmeter

Fig 2
Variable Voltage Test Connections

(1) The mechanical means of locking the rotor must be of adequate strength to prevent possible injury to personnel or damage to equipment.

(2) The direction of rotation must be determined prior to this test so that methods of fastening and of measuring torque can be properly applied.

(3) The current and torque readings must be taken at approximately rated voltage and at rated frequency, and the motor must be at approximately ambient temperature. The ambient temperature should be between 20 °C and 30 °C. The voltage shall be within 5% of rated voltage. The ammeter reading shall be corrected by multiplying it by the rated voltage and dividing the product by the voltage reading when the ammeter was read. The ammeter shall be read after its pointer has stopped its periodic swinging but all readings shall be taken within three seconds after the line switch is closed. The temperature at the start of every test shall not be less than 20 °C nor more than 30 °C, unless otherwise agreed to by the purchaser and manufacturer.

5.7 (All) Torque. The torque may be measured with rope and pulley, by dynamometer, with a brake or beam, with a rotating-shaft torque sensor, or by stator reaction. All motors are subject to variations in locked-rotor torque and these variations depend upon the angular position of the rotor with respect to the stator. The locked rotor torque is defined as the minimum torque developed at rest in any angular position of the rotor with the entire motor at a temperature of not less than 20 °C,

nor greater than 30 °C. The minimum locked rotor torque is best observed by plotter test method of locked rotor torque versus rotor angular position, but can also be determined approximately by direct measurement tests at several angular positions of the rotor.

5.8 (All) Power. Readings of power shall be taken simultaneously with those of current and torque, except for continuous data acquisition in the sequential mode.

5.9 Tests for Speed-Torque and Speed-Current. The speed-torque characteristic is the relation between torque and speed, embracing the range from zero to synchronous speed. This relation, when expressed as a curve, will include breakdown (maximum running) torque, pull-up (minimum running) torque, and locked-rotor torque of induction motors and also pull-in torque for synchronous motors. The speed-current characteristic is the relation between current and speed. (This curve is generally plotted on the same sheet as the speed torque curve, using a common speed scale for both curves.) For these tests the motor winding temperature should be its normal operating temperature.

5.9.1 Method. The speed-torque and speed-current tests should be made by a continuous data acquisition method. When equipment for continuous data acquisition is not available, these tests may be made with a dynamometer or by rope and pulley method. Tests shall be made at or near rated voltage using a regulated power supply. When the dynamometer or rope and pulley method is used, the speeds at which torque is determined shall be chosen at such intervals as to permit plotting the maximum torques of the fundamental characteristics; and also to permit the plotting of the maxima and minima of synchronous or asynchronous irregularities caused by higher order harmonics when they are present in an appreciable degree.

5.9.2 Switching Torque. The switching torque of a motor which has an automatic connection change at some instant in its starting interval is the minimum external torque developed by the motor as it accelerates through switch-operating speed. It should be noted that if the torque on the starting connection is never less than the switching torque, the pull-up torque is identical with the switching torque. However, if the torque on the starting connection falls below the switching torque

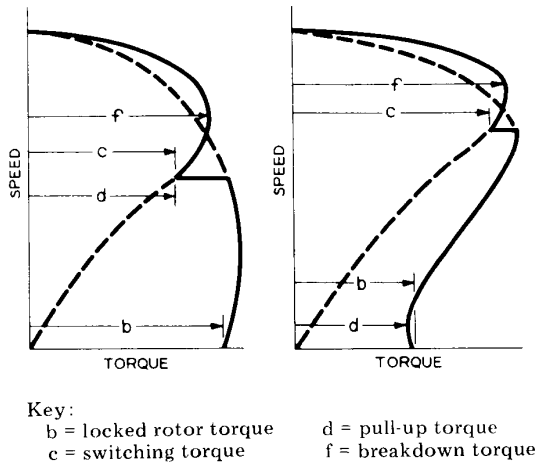

Fig 3
 Torques of a Single-Phase Induction Motor

at some speed below switch-operating speed, the pull-up and switching torques are not identical. The difference between pull-up and switching torque is illustrated in Fig 3.

The switching torque may be determined by the following procedure. The motor is allowed to run at no-load and the torque load is gradually increased until the speed falls off abruptly and the starting switch recloses. With this torque setting the motor may either fall off in speed or *pump*, that is, the speed may cycle between the upper and lower speeds. In either case the torque load should be reduced until the motor transfers and remains on the running connection.

An alternative method is to start the motor from rest with a heavy load and then gradually decrease the torque until the motor transfers and remains on the running connection.

5.9.3 Pull-In Torque. The pull-in torque of a synchronous motor is the maximum constant external torque under which the motor will pull its connected inertia load into synchronism at rated voltage and frequency. Because the inertia of the connected load (often unknown) greatly affects the pull-in torque, the pull-in torque is defined in this procedure as that pull-in torque measured with no appreciable external inertia.

Either a brake or a cord and pulley may be used to measure the pull-in torque, but a dynamometer should not be used.

If the inertia of the load is known and can

be simulated on test, the pull-in torque may also be measured under this condition if it is so desired.

5.9.4 Breakdown Torque. This test is best performed by the continuous data acquisition method. Direct measurement methods are also adequate but are more dependent on operator skill. When a direct measurement method is used, this test may be made by allowing the motor to run light and then increasing the torque until the speed of the motor falls off abruptly. This test should be made as rapidly as possible, consistent with accuracy, but not so rapidly as to introduce inertia errors into the readings.

5.9.5 Pull-Out Torque (Synchronous Motors). This test may be made by allowing the motor to run light in synchronism and then gradually increasing the torque until the motor pulls out of synchronism.

5.9.6 Pull-Up Torque. The pull-up torque of an alternating-current motor is the minimum external torque developed by the motor during the period of acceleration from rest to the speed at which breakdown torque occurs. For motors which do not have a definite breakdown torque, the pull-up torque is the minimum torque developed up to rated speed.

The pull-up torque may best be determined by continuous data acquisition method, but may also be determined by brake, dynamometer, or rope and pulley.

5.9.7 Formula for Load Torque. The load torque of any motor can be calculated from the following equation:

$$\text{torque} = \frac{k \cdot P}{n}$$

in which

n = rotational speed in r/min

If

P = output in horsepower

then

$$\begin{aligned} k &= 5252 \text{ for } T \text{ in lb}\cdot\text{ft} \\ &= 63020 \text{ for } T \text{ in lb}\cdot\text{in} \\ &= 84030 \text{ for } T \text{ in oz}\cdot\text{ft} \\ &= 1008000 \text{ for } T \text{ in oz}\cdot\text{in} \end{aligned}$$

If

P = output in kilowatts

then

$$k = 9549 \text{ for } T \text{ in N}\cdot\text{m}$$

6. Speed Measurements

6.1 Mechanical Methods. A mechanical tachometer with a rubber tip to fit the end of the shaft may be used to measure speed if precautions are observed to assure the tester that the tachometer shaft runs at the same speed as the motor shaft. The directly connected tachometer must not be used, however, if the mechanical load which it imposes on the shaft is an appreciable portion of the total shaft load.

6.2 Visual Methods or Other Means that Impose No Appreciable Load (Stroboscopic or Electronic Impulse Counter). When a motor of approximately $\frac{1}{20}$ hp or less is to be tested, visual means for determining the speed should be employed because the added load of a tachometer would introduce too much error. Either an electric or a mechanical stroboscope is satisfactory if accurately calibrated. However, if the speed of an induction motor is not more than approximately 100 r/min less than its synchronous speed, the speed may be determined very accurately by using an electric stroboscope to determine the slip and then subtracting the slip from the synchronous speed. The frequency must, of course, be accurately known.

6.3 Continuous Data Acquisition Method. Speed measurement can be performed in a continuous manner by using a dc tachometer, an ac tachometer with suitable rectifying means, or a rotary-pulse generator. Except in the case of a dc tachometer, additional means for direction sensing are required.

7. Temperature Tests for Stable Conditions

7.1 Purpose. Temperature tests are made to determine temperature rise of certain parts of the motor above the ambient temperature when the motor is running at specified loading condition. The following paragraphs are guides for test procedure and treatment of data.

7.2 General Instructions. The motor shall be shielded from air currents coming from pulleys, belts, and other outside sources. A very slight current of air may cause great discrepancies in heating results. Conditions which produce rapid change in ambient air temperature shall not be considered satisfactory for temperature tests. Sufficient floor space should be pro-

vided between machines to allow free circulation of air.

7.3 Temperature Measuring Devices. Temperature measuring devices shall be in accordance with IEEE Std 119-1974 [8]. At the start of the temperature tests all instruments shall be checked to make certain that there are no appreciable instrument errors or stray field effects.

7.4 Methods of Measuring Temperature. The commonly used methods for measuring temperature are listed below. It may be desirable to use one of these as a check on another (see IEEE Std 1-1969 [5], Table 2).

(1) Thermometer method (using liquid-in-glass thermometer, resistance thermometer, or thermocouple)

(2) Applied thermocouple method

(3) Resistance method

The thermometer method is usually not as accurate as the other two methods for measuring the temperatures in small fractional-horsepower motors because of the difficulties encountered in properly placing the thermometer. Furthermore, thermocouples do not conduct away as much of the coil heat as do thermometers. The applied thermocouple method is quite often used in conjunction with either the thermometer or resistance method.

7.4.1 Thermometer Method. Liquid-in-glass thermometers, before being used, should be examined for broken liquid columns. When the thermometer is in position its bulb must not be higher than its stem. The bulb should be secured in position with a felt pad, a small piece of putty, or the equivalent, in such a manner as to shield it from the surrounding air. There should be no restriction of the natural windage of the motor or of the heat radiation from the coil of which the temperature is being measured. The liquid-in-glass thermometer, resistance thermometer, or thermocouple is applied to the hottest parts accessible to ordinary liquid-in-glass thermometers without alteration of the structure. The temperature shall be measured on the surface of the coil ends at two peripherally spaced locations.

7.4.2 Applied Thermocouple Method. In using this method, thermocouples are applied to the conductor insulation in the hottest parts accessible to them. After being well tucked in they are covered with a small piece of putty or modeling clay.

7.4.3 Resistance Method. The average temperature throughout a motor winding is determined by comparing the resistance of the winding at the temperature to be determined with the resistance at a known temperature. Extreme care shall be taken to secure accurate resistance measurements because a small error will cause a comparatively large error in the calculated temperature. The cold resistance must be taken only after the motor has remained in a constant ambient long enough that the winding is at that ambient temperature. Resistance measurements shall be made as outlined in IEEE Std 119-1974 [8]. The following equation applies:

$$t_h = \frac{R_h}{R_c} (K + t_c) - K$$

in which

t_h = total average temperature of winding in °C when hot resistance R_h was measured

t_c = total average temperature of winding in °C when cold resistance R_c was measured

R_h = hot resistance, in Ω

R_c = cold resistance, in Ω

K = 234.5 for copper
= 225 for aluminum

7.4.4 Seely's Method. This method and the circuit for it are described in IEEE Std 119-1974 [8].

7.4.5 Core. Core temperature readings should be taken in at least two peripherally spaced locations on the external surface of the core near the vertical centerline. Alternate locations on the outside of the frame near the vertical centerline may be used. Liquid-in-glass thermometers or thermocouples may be used.

7.4.6 Bearings

(1) *Liquid Film Type (sleeve or thrust).* The temperature readings should be those taken at a point as near the bearing surface as possible.

(2) *Ball or Roller Type.* The temperature readings should be those taken at a point on the stationary race.

(3) *Lubricant.* It is customary to measure the temperature of oil lubricants. The temperatures of oil in the reservoirs should be taken.

7.4.7 Measurement of Ambient Temperature. For the procedure to be followed in the measuring of ambient temperatures of electric machines the recommendations of IEEE Std 119-1974 [8] shall be followed.

7.5 Procedure. The motor shall be loaded by Method B outlined in Section 5 or by other means whereby the load may be adjusted and held constant. The test shall be made at rated voltage and frequency. The loading may be determined by direct measurement of input or output power. A motor having more than one rating shall be tested at the rating which produces the greatest temperature rise. If it is not known which loading will produce the greatest temperature rise, the motor shall be separately tested at every rating.

The test shall be continued for the specified time (for motors not continuously rated) or until constant temperatures have been reached. Unless otherwise specified a short-time test shall commence only when the motor parts are within 5 °C of the ambient temperature.

For continuously rated motors, readings of temperatures shall be taken at intervals not exceeding 30 min for integral-horsepower motors and not exceeding 15 min for fractional-horsepower motors.

The measurements of temperatures after shutdown of electric apparatus requires quick stopping of the motor at the end of the temperature test. Temperatures should be measured of the hottest parts that can be made quickly accessible by the removal of covers or small parts. Temperatures after shutdown shall be measured as frequently as possible until the temperature readings have begun a decided decline from their maximum values. If thermometers are used, they should be preheated to nearly the expected temperature.

7.6 Temperature Rise. When the motor is ventilated by the immediately surrounding air, the temperature rise is the observed motor temperature less the ambient temperature. When the motor is ventilated by air obtained from a remote source, the temperature rise is the observed motor temperature less the temperature of the ingoing air. The observed motor temperature shall be considered to be the maximum temperature reading obtained prior to or after shutdown.

8. Measurement of Rapidly Changing Temperature on Windings

8.1 Purpose and Scope. The purpose of this section is to describe the methods used for the

measurement of rapidly changing temperatures of single-phase fractional-horsepower induction motor windings and to give information regarding the characteristics and limitations of these methods and of the instruments used.

8.2 Classification of Methods. The fundamental methods of measuring motor-winding temperature are described in IEEE Std 1-1969 [5], IEEE Std 118-1978 [7] and IEEE Std 119-1974 [8].

This section will comment on these fundamental methods from the viewpoint of measuring rapidly-changing winding temperature.

8.2.1 Various Methods. These fundamental methods of temperature determination are defined in IEEE Std 1-1969 [5], Table 2, and are

- (1) Thermometer
- (2) Applied thermocouple
- (3) Contact thermocouple
- (4) Resistance
- (5) Embedded detector

These methods of measuring motor-winding temperature can be classified into two categories depending upon their fundamental principle of operation. One category consists of methods employing a temperature-sensing element located in thermal contact with the windings. The thermocouple thermometer is an example of a sensing element used in this way. The other category includes those methods that sense the change of a physical property of the winding conductor material with temperature. The resistance method is an example of this and has as its basis the change of electrical resistivity with temperature.

8.2.2 Temperature Sensing Elements, General Comments. The value measured with temperature-sensing elements applied to motor windings depends upon the flow of heat from the winding conductor material to the element. Because of the thermal gradient resulting from this heat flow, sensing elements cannot measure the true conductor temperature without error if the conductor temperature is changing. The magnitude of this error arising from heat flow or thermal lag is dependent upon:

- (1) Rate of change of the winding conductor temperature
- (2) Thermal resistance between the winding conductor and the sensing element
- (3) Thermal capacity of the sensing element
- (4) Thermal conductance between the element and the ambient

8.3 Instrumentation — General. Errors of considerable magnitude can result from the manual reading and recording of changing temperatures on manual instruments or on automatic instruments of the indicating type. For this reason, it is recommended that automatic balancing and continuous recording instruments be used. The recording instrument should have a speed of response sufficiently fast that it can follow closely the changing temperature.

8.4 Thermometer Method. Bimetallic, liquid-in-glass, and resistance thermometers are in general not recommended for use in measuring transient temperatures of motor windings. The size and shape of these thermometers make them difficult to apply to windings. Their readings also may be quite erroneous because of their large thermal capacity and because of the low thermal conductance from this capacity to the windings.

8.5 Applied Thermocouple Method. The applied thermocouple method is defined in IEEE Std 1-1969 [5], Table 2, as, "thermocouples are applied directly to the conductors or separated from the metallic circuit only by the integrally applied insulation of the conductor itself."

Integrally applied insulation for purposes of this standard is interpreted to include the varnish impregnation normally applied to motor windings.

Because the temperature reading of the thermocouple lags the winding temperature when it is changing, thermocouple temperature continues to increase after winding de-energization. Hence winding temperature being measured by thermocouple should be the highest recorded reading, and this may be reached after de-energization.

8.5.1 Applied Thermocouple Method of Application — General. The thermocouple junction may be soldered directly to the metallic conductor of the winding or held against the integrally applied insulation. For the latter, two basic methods of holding the thermocouple in position are by cementing and by means of securing with a felt pad tied to the windings. These three methods will be discussed separately.

8.5.2 Thermocouples. Iron-constantan thermocouples of 0.25 mm (0.010 in) diameter wire are recommended because of the

relatively low heat flow from the junction out through the thermocouple wires. Because of this heat flow effect, copper-constantan thermocouples and thermocouples made of wire greater than 0.25 mm (0.010 in) in diameter are not recommended.

Thermocouples made of wire smaller than 0.25 mm (0.010 in) in diameter in general are fragile and therefore difficult to apply; they also may offer problems of accuracy of the thermoelectric potential generated at the junction unless calibrated before being used. Thermocouple junctions may be formed by welding or soldering. The twisting of the wire at the junction should be kept to a minimum by removing any excess after forming so that the junction mass is as small as possible.

Thermocouple wire used should be of known calibration.

8.5.3 Cemented. In this method, the thermocouple (see 8.5.2) is mechanically held against the winding by means of a cement. The cement used should not have a deleterious effect on the insulation. A commonly used cement is a mixture of fuller's earth and waterglass.

8.5.3.1 Cemented, Method of Application

(1) Because of the random buildup of varnish on motor winding and of the resulting variation of the thermal resistance between the thermocouple and the winding and the variation in temperature at different points of the winding, it is recommended that a sufficient number of thermocouples be applied to each energized motor winding under test to increase the probability of finding the hottest accessible area. (Experience has shown that at least four thermocouples at each end of each energized winding are needed; the highest temperatures are usually obtained at the thinly varnished end.)

(2) The thermocouple junction should be in thermal contact with the integral insulation of the winding conductor.

(3) The point of attachment of the thermocouple to the coil bundle is determined by visual examination. Experience has shown that the hottest accessible location on an induction motor winding is usually at the top winding bundle midpoint of the span and midway on the bundle. The point selected should be away from any larger conductors or connecting wires and away from the stator iron. Heavy mass items such as these, if close to the location of the thermocouple junction, tend to conduct

heat away from this area of the winding conductor and reduce the temperature reading of the thermocouple junction.

(4) The preferred procedure is to place the thermocouple junction directly on top of a wire which is recessed between two adjacent wires in the bundle. The cement is then applied directly over the thermocouple junction, thereby cementing the junction in direct contact with the wire as well as having the cement bridge across the two adjacent wires.

(5) The thermocouple junction prior to attaching to the motor winding should not be coated with any insulating material, as this not only increases its mass but decreases the thermal conductance between it and the winding conductor.

(6) A minimum amount of cement should be used to hold the thermocouple junction in position against the winding so that the mass surrounding the junction will be as small as possible.

(7) Care must be taken to be sure the thermocouple junction is in direct contact with the integrally applied insulation of the conductor and that there is no cement between the two.

(8) A sufficient length of time or temperature soaking should be allowed to drive off volatiles in the cement prior to testing. A fuller's earth and waterglass mixture, when used as the cement, should be allowed to dry and be conditioned by being heated to the highest expected temperature before starting the test. (About ten hours drying time at room temperature is usually sufficient.)

(9) The thermocouple lead wire should be tied against the motor windings a sufficient distance before being brought out in order to minimize the transfer of heat from the junction out through the thermocouple leads. (For example, this may extend two to three inches or completely around the circumference of the windings, whichever is shorter.)

8.5.3.2 Cemented — Range of Usage. Range of usage is determined by the type of thermocouple wire and cement used. The temperature range considered by this standard extends to 350 °C.

8.5.3.3 Cemented — Instrumentation. It is recommended that a self-balancing and continuously recording potentiometer be used. This is necessary to eliminate the error which results from the variable human element involved in reading manually balanced or indi-

cating type meters. The potentiometer used should have a speed of response consistent with the expected rate of change in temperature of the winding being measured.

8.5.3.4 Cemented — Advantages

(1) The small size of the thermocouple junction permits its location at many accessible parts of the winding.

(2) It is relatively fast in its response to surrounding temperature as compared to thermometers.

(3) It provides through its proper instrumentation a continuous record of winding temperature.

8.5.3.5 Cemented — Disadvantages

(1) Thermal lag is inherent in surface-mounted thermocouples so that instantaneous peak temperature cannot be measured. The thermocouple reading continues to rise after the motor winding is de-energized so that a reading cannot be taken at the instant of de-energization.

(2) It is not possible to obtain hottest-spot temperatures since applied thermocouples give only accessible surface-winding temperature.

(3) Repeatability of test results using this method is difficult due to the difference in subsequent mounting of thermocouples.

(4) A number of thermocouples are required to obtain consistent results.

(5) Drying out of volatiles in cement requires time so that motor testing is delayed until some time after thermocouples are applied.

(6) There is a possibility of physical damage to the motor windings.

8.5.4 Felt Pad. This method is similar to the cemented method and differs in the manner by which the thermocouple junction is secured to the motor winding. Here the junction is mechanically held against the winding by being tied in position with suitable string after a square felt pad, approximately 6.4 mm (0.25 in) and 1.6 mm (0.063 in) thick, is placed over the junction.

Method of application, range of usage, instrumentation, advantages, and disadvantages are the same as given for 8.5.3.1 through 8.5.3.5 except there is little likelihood of damaging windings and the drying time of cement is eliminated. However, the possibility exists of locating the thermocouple junction in a void in the winding and of not measuring actual winding insulation temperature. Temperature values

obtained generally are of the same level as with cemented thermocouples.

8.5.5 Soldered. This method requires the thermocouple junction to be attached directly to the metallic winding conductor by soldering. The composition of the solder should be such that the melting point is above the maximum temperature to be measured. A discontinuity in the heating or cooling curves usually indicates that a higher temperature solder should be used.

8.5.5.1 Soldered — Method of Application

(1) The point of attachment is selected visually in the same manner as described in 8.5.3.1(3). A sufficient number of thermocouples should be installed to increase the probability of finding the hottest accessible area. (Experience has shown that higher temperature readings are generally obtained at the thinly varnished end and at the top coil bundles, and that generally two thermocouples at this preferred location are needed.)

(2) The winding conductor is prepared by removing the insulation after a strand has been loosened from the bundle. Suitable heat-insulating material is inserted behind the bared strand to protect the insulation of the remaining conductors during soldering. A thin application of solder is made to the conductor. The thermocouple junction which has previously been formed by twisting and soldering is placed across the conductor at the selected location and fused in place by applying heat from the soldering tip without adding any further solder. The junction should be attached at its first twist and any excess length should be cut off. The insulating barrier is then removed and the strand gently pushed back towards the bundle, scant of touching the insulated conductors.

(3) The thermocouple lead wire should be tied against the windings in the same manner as in 8.5.3.1(9).

8.5.5.2 Soldered — Range of Usage. The procedure is the same as 8.5.3.2 except as limited by the melting point of the solder used. Use of the correct type solder for the temperature range to be measured is necessary to avoid false readings.

8.5.5.3 Soldered — Instrumentation. The procedure is the same as 8.5.3.3 with the added requirement that the instrument case, drive, and alternating-current balancing system be isolated electrically from the thermocouple circuit

and from the alternating-current supply to the instrument so that the voltages picked up by the thermocouple will neither affect the instrument reading nor damage the instrument.

8.5.5.4 Soldered — Advantages. The procedure is the same as 8.5.3.4. In addition, this method generally provides temperature readings of the same level or somewhat higher than the highest levels listed in 8.5.3. The temperature override of the junction is generally negligible and when present, indicates poor installation.

8.5.5.5 Soldered — Disadvantages

(1) It is not possible to obtain the hottest-spot temperature since soldered thermocouples give conductor temperature only at accessible points of measuring.

(2) There is physical damage to the winding.

(3) Electrical isolation of the measuring circuit is required.

(4) The thermal characteristics of the conductor being measured may be different from the original coil bundle.

(5) Repeatability of test results using this method is difficult due to differences in subsequent mountings of thermocouples.

(6) A number of thermocouples is required to obtain consistent results.

(7) Considerable skill and the proper choice of solder are required to avoid errors.

8.6 Contact Thermocouple Method. Contact thermocouple method is defined in IEEE Std 1-1969 [5], Table 2, as follows: "Consists in the determination of the temperature by the application of pointed prods, made of dissimilar metal, to an exposed bare-metal surface so that the metal whose temperature is to be measured forms part of a thermocouple circuit."

The standard references this method as suitable for measuring temperatures of bare-metal surfaces such as those of commutator bars and slip rings. This method is not normally used for measuring winding temperature.

8.7 Resistance Method. Resistance method is defined in IEEE Std 1-1969 [5], Table 2, as, "Determination of the temperature by comparison of the resistance of a winding at the temperature to be determined with the resistance at a known temperature." The average temperature of the winding is obtained.

The principal methods of measuring winding resistance are voltmeter-ammeter or drop-of-potential, ohmmeter, Wheatstone bridge, and

Kelvin double bridge.

8.7.1 Resistance — Method of Application

(1) Temperature determination by the change of resistance method consists in determining the electrical resistance (R_c) and temperature (t_c) of a cold winding and the electrical resistance (R_h) of the hot winding. The hot temperature (t_h) is then calculated from the equation given in IEEE Std 118-1978 [7], 5.2, which may be written as follows:

$$t_h = \frac{R_h}{R_c} (t_c + K) - K$$

For temperature in degrees Celsius, K is 234.5 for copper and 225.0 for aluminum.

(2) Cold resistance should be measured after the motor has been exposed to the test-room ambient for a sufficient time for the entire motor to be at room temperature. The cold-winding temperature may then be measured by a reliable temperature measuring device.

(3) For measurement after shutdown with rapidly varying temperature, the objective is to obtain the initial hot resistance reading as quickly as possible after shutdown before any appreciable cooling of the winding has occurred.

(4) When the circuit of an alternating-current energized-motor winding is opened, a transient voltage momentarily appears. This transient is very low in magnitude and separate from any high-value transient induced by sudden opening of the circuit. Therefore, a means is required for taking the resistance measurement after a time delay to allow the low-value transient to disappear and not affect the reading. Using automatic instrumentation, the initial reading can be recorded within ten seconds thereby eliminating the need for extrapolating values to zero time.

(5) Switching accomplished automatically involves electric contacts in the measuring circuit. Consideration of a contact resistance can be eliminated from the measurement with the drop-of-potential method using a potentiometer to obtain a null current balance. For the Wheatstone bridge or ohmmeter methods, contacts should be of low resistance and particularly of the type whose resistance will remain constant in the low-power circuit involved.

(6) Transient values at switching may be kept from being recorded on automatic equipment by providing an electrically actuated lifting de-

vice for the recording pen. The pen-lift mechanism, when interlocked in the proper sequence in the switching circuit, permits the pen to record only pertinent readings.

(7) The same instrumentation should be used in taking the cold and hot measurements.

8.7.2 Resistance — Range of Usage. The drop-of-potential method with readings by potentiometer may be used over the wide range of low- and high-resistance values found in fractional-horsepower motor sizes. A Kelvin double bridge should be used for resistances below 1.0Ω . The Wheatstone bridge method (using the three-lead type bridge) may be used for windings of cold resistance approximately 1.0Ω and above. For windings of cold resistance of 5Ω or higher, any of the methods in Section 8 may be used. Temperatures determined from resistance readings are stated in IEEE Std 118-1978 [7], 5.2, to apply for commercial grades of copper and aluminum conductors. The constant K in the formula of 8.7.1, which is 234.5 for copper and 225.0 for aluminum, provides results of the accuracy intended in this standard over a temperature range of 0°C to 300°C .

8.7.3 Resistance — Instrumentation

(1) The use of self-balancing recording instruments is recommended.

(2) In the drop-of-potential method, a simplified approach is the use of a constant direct-current power supply and a potentiometer to record the voltage drop across the winding. With the current adjustable and suitable zero suppression on the potentiometer, the recording chart may be calibrated to read temperature directly.

(3) In the Wheatstone bridge method, a three-lead type bridge is recommended to eliminate lead resistance. The resistance of the contacts in the external circuit should be low and constant in value (see 8.7.1(5)).

8.7.4 Resistance — Advantages

(1) The resistance measurement method has an inherent advantage of rapid response and no thermal lag as compared to a sensing element such as a thermocouple. Hence, the thermal gradient error resulting from heat flow is eliminated.

(2) Repeatability is inherent in this method so that good correlation of results can be obtained by different groups performing similar tests.

(3) In many cases the motor may not require

disassembly or more than removal of an end shield for lead connections. In these cases, there is little likelihood of damaging the winding and the motor may be placed on test immediately after connections are made.

8.7.5 Resistance — Disadvantages

(1) This method measures only average conductor temperature.

(2) Different means must be used for measuring the temperature of motor parts other than the winding.

(3) An accurate determination of the cold resistance temperature value is required.

(4) For other than the drop-of-potential method with potentiometer, errors may be introduced by changes in contact resistance of switching relays or at lead connections unless precautions are taken.

(5) It may be necessary to change wiring connections of associated apparatus.

(6) Some motors will require modification to permit connections to the winding.

8.8 Embedded-Detector Method. The embedded-detector method is defined in IEEE Std 1-1969 [5], 1-14, as follows: "Consists in the determination of the temperature by thermocouples or resistance temperature detectors built into the machine, either permanently or for test purposes, in specified locations inaccessible to mercury or spirit thermometers."

8.8.1 Embedded Detector — Use. This method is useful to the design engineer during development of new motor designs to investigate hot spots and temperature gradients. In using this method, precautions should be taken similar to those for the applied-thermocouple method.

8.8.2 Embedded Detector — Limitations. This method does not lend itself for use on routine checks of winding temperature and, also, it is not suitable for use on a motor already built as provision for its use must be made at the time the motor stator is wound.

8.9 Summary

(1) For measurement of rapidly changing winding temperatures, two of the methods discussed, namely thermometer and contact thermocouple method, are not applicable.

(2) With the applied thermocouple method, repeatability of test results requires care in applying the thermocouple and requires that a sufficient number of thermocouples be used.

(3) For determination of hot-spot tempera-

ture, the embedded-detector method is recommended.

(4) The resistance method is capable of good correlation of results by different groups performing similar tests.

(5) The soldered thermocouple method is not generally used for verification testing as it damages the winding insulation. It is essentially a research tool that may be used for special investigation.

9. Miscellaneous Tests

9.1 Insulation Resistance. Insulation resistance tests are not usually made on new motors unless they are specifically requested. For maintenance purposes, insulation tests are of some value.

For test methods, ANSI/IEEE Std 43-1974 [2] should be followed.

9.2 High-Potential Test. In the interests of safety, precautions should be taken to prevent anyone from coming in contact with any part of the circuit or apparatus while high-potential tests are in progress.

The high-potential test voltage shall be applied successively between every electric circuit and the frame with any other metal parts, including other windings connected to the frame. No leads shall be left unconnected during the test because such a condition may produce an extremely severe strain on windings connected to those leads. In making the test, the voltage shall be increased to full value as rapidly as is consistent with its value being correctly indicated by the voltmeter, and the full voltage shall be maintained for one minute. The voltage should then be reduced at a rate that will bring it to one-quarter of its highest value or less in not more than 15 s. Motors produced in large quantities should be subjected to 20% excess voltage for one second. (See ANSI/NEMA MG1-1978 [4].)

Capacitors of capacitor-type motors must be left connected to the windings in a normal manner. In making these tests, care should be taken to impress only the desired value of voltage on the windings. A sudden application of the test voltage may cause surges of dangerous

overvoltage. One method of overcoming this difficulty is that of using a variable resistor in the primary circuit of the test transformer and then cutting the resistor out after the potential has been applied. An alternative method is that of using a suitable choke in the primary of the test transformer to limit the possible surges. It is possible to inadvertently obtain overvoltages on the motor through a resonant or partially resonant condition between the capacitance of the winding (to ground) and the leakage reactance of the testing transformer. To obtain most accurate results, the test voltage should be measured by a direct-reading electrostatic voltmeter or by an oscilloscope. More details on the dielectric test are available in ANSI/IEEE Std 4-1978 [1].

9.3 Noise. See IEEE Std 85-1973 [6].

9.4 Vibration. Both horizontal and vertical vibration measurements shall be made at the motor bearing housing. The double amplitude on either end in either direction is to be taken as the measure of vibration.

Mounting arrangements will affect the vibration of a motor. In order that measurements may be obtained independent of mounting methods as nearly as possible, the motor shall be placed on flexible mountings or pads. These pads or springs shall compress by the weight of the motor alone in amounts not less than the values shown in the following table:

Speed (r/min)	Minimum Compression	
	(in)	(mm)
900	1	25.4
1200	$\frac{9}{16}$	14.3
1500	$\frac{3}{8}$	9.5
1800	$\frac{1}{4}$	6.4
3600	$\frac{1}{16}$	1.6
7200	$\frac{1}{64}$	0.4

The pads or springs shall be so selected that their compression is not more than one-half the original thickness.

9.5 Overspeed. Overspeed tests are rarely made on induction motors. If such a test is specified, every precaution shall be taken to protect personnel and equipment.

**Form 2 (Typical)
Report of Complete Test of Single-Phase Motor**

Name of Manufacturer
 Address of Manufacturer
 Name of Purchaser
 Address of Purchaser
 Application (Intended Use)
 Date of Test
 Purchaser's
 Order Number

Nameplate Information

Power (hp)	Synchronous Speed (r/min)	Full-Load Speed (r/min)	Frequency (Hz)	Potential (V)	Current (A) Full-Load	Type	Frame Number	Style Number

Conditions of Test				Temperature Rise (°C)	
				Stator	Rotor
				Windings	Windings
				(Cross out two) by Resistance Thermometer Thermocouple	(Cross out two) by Resistance Thermometer Thermocouple
Hours Run	Potential (V)	Current (A)	Cooling Air (°C)		

Method of Testing (Cross out two) A B C

Performance Characteristics

Slip r/min full load	Current amperes no load	Resistance ohms at 25 °C.	Breakdown Torque (Cross out three) oz f·in oz f·ft lb f·ft N·m	Locked Rotor Torque (Cross out three) oz f·in oz f·ft lb f·ft N·m %V	Locked Rotor Current amperes %V	High-Potential Test Voltage Start Windings Run Windings
		Start Windings — Run Windings —				

Efficiencies and Power Factors

Efficiency (%)			Power Factor, (%)		
Full Load	$\frac{3}{4}$ Load	$\frac{1}{2}$ Load	Full Load	$\frac{3}{4}$ Load	$\frac{1}{2}$ Load

Notes
 Data from test on motor Approved by Engineer
 (this or duplicate)
 Date

Form 3 (Typical)
Input-Output Test of Single-Phase Motor

Power . . . (hp) Frame . . . Frequency . . . (Hz) Potential . . . (V) Temperature Rise . . . (°C)

Time Rating Synchronous Speed

Test Points	1	2	3	4	5	6	7
(t) Stator Winding Temperature (°C)							
Ambient Temperature (°C)							
Frequency (Hz)							
Observed Slip (r/min)							
Corrected Slip (r/min)							
Speed (r/min)							
Torque (oz f·in or kg f·m or N·m)							
(1) Dynamometer Correction							
(2) Corrected Torque							
(3) Horsepower Output							
Line Current (A)							
Power Factor (%)							
Power Input (W)							
(a) Stator I^2R loss at t_s (°C)							
(b) Stator I^2R loss at t (°C)							
(4) Input Correction = (a) - (b)							
(5) Correct power input (W)							
(6) Efficiency (%)							

Performance Curve Number _____

Data Obtained from Performance Curve

Load as Fraction of Rated Load	0	$\frac{1}{4}$	$\frac{1}{2}$	$\frac{3}{4}$	1.0	$1\frac{1}{4}$
Power Factor (%)						
Efficiency (%)						
Speed (r/min)						
Line Current (A)						

Tester _____ Date _____